

CV-305MLR

3G/HD/SD-SDI to HDMI Converter
with Audio Extraction and Mixer

User Manual



3G-HD-SD HDMI™
HIGH-DEFINITION MULTIMEDIA INTERFACE



rev: 140509
Made in Taiwan



Safety and Notice

The **CV-305MLR 3G/HD/SD-SDI to HDMI Converter with Audio Extraction and Mixer support** has been tested for conformance to safety regulations and requirements, and has been certified for international use. However, like all electronic equipments, the **CV-305MLR** should be used with care. Please read and follow the safety instructions to protect yourself from possible injury and to minimize the risk of damage to the unit.

- Follow all instructions and warnings marked on this unit.
- Do not attempt to service this unit yourself, except where explained in this manual.
- Provide proper ventilation and air circulation and do not use near water.
- Keep objects that might damage the device and assure that the placement of this unit is on a stable surface.
- Use only the power adapter and power cords and connection cables designed for this unit.
- Do not use liquid or aerosol cleaners to clean this unit. Always unplug the power to the device before cleaning.



TABLE OF CONTENTS

INTRODUCTION	1
FEATURES.....	1
PACKAGE CONTENTS.....	1
SPECIFICATIONS	2
PANEL DESCRIPTIONS	3
CONNECTION DIAGRAM.....	4
SUPPORTED RESOLUTIONS.....	5
NOTICE	5
WARRANTY	6

INTRODUCTION

The **CV-305MLR** provides a professional way to convert 3G/HD/SD-SDI to HDMI Converter with audio extraction and mixer in real time. The conversion between SDI and HDMI is pure digital and guarantees no loss transformation for both audio and video. Plus, with up to 8 channels audio support, 7.1 channel or 5.1 channel audio becomes available. The CV-305MLR also provides one low jitter SDI local loopout. With the use of CV-305MLR, the most popular uncompressed video interface in the consumer world is readily available for professional SDI equipments!

FEATURES

- Supported high-definition (HD) formats:
NTSC 525@59.94, PAL 625@50, 720p@50,720p@59.94, 720p@60, 1080i@50, 1080i@59.94, 1080i@60, 1080p@23.97, 1080p@24, 1080p@25, 1080p@29.97, 1080p@30, 1080p@50, 1080p@59.94, 1080p@60
- Bit Rate: 2.97 Gbps, 2.967 Gbps, 1.485 Gbps, 1.4835 Gbps, 270 Mbps
- Auto 3G/HD/SD-SDI detection
- HDMI 1.2a supported
- One SDI compliant output and one HDMI compliant output
- Support Analog stereo and S/PDIF audio outputs

PACKAGE CONTENTS

- 1x CV-305MLR
- 1x 5V power adapter
- 1x User Manual

SPECIFICATIONS

Model Name	CV-305MLR	
Technical		
SDI standards	3G-SDI & HD-SDI & SD-SDI	
Auto HD/SD-SDI detection	Yes	
Video bandwidth	[2.97Gpbs & 2.975/1.001Gbps]	
Video support	[3G] 1080p50/59.94/60 (4:2:2) [HD] – 720p @50/59.94/60Hz, 1080i@50/59.94/60Hz, 1080p@24/30Hz [SD] – NTSC @59.94Hz, PAL @50Hz	
Input signal	[SD-SDI] SMPTE 259M [HD-SDI] SMPTE 292M, 296M [3G-SDI] SMPTE-424M	
Output signal	SDI	
Output impedance	75Ω	
Synchronization mode	Internal synchronization or external synchronization	
Eye pattern characteristics	Extra low alignment jitter 0.05UI at HD	
Cable equalization	[3G-SDI] up to 90m (300ft) [HD-SDI] up to 150m (500ft) [SD-SDI] up to 300m (1000ft)	
Audio support	Support 2ch/ 7.1ch	
PCB stack-up	6-layer board [impedance control — differential 100Ω; single 50Ω]	
Input	1x SDI	
Output	1x HDMI + 1x SDI + 2x RCA + 1xS/PDIF	
BNC connector	75Ω inter-locked socket	
HDMI connector	Type A [19-pin female]	
RCA connector	S/PDIF audio/2ch stereo audio	
Mechanical		
Housing	Metal enclosure	
Dimensions (L x W x H)	Model	92 x 83 x 28mm [3.6" x 3.3" x 1.1"]
	Package	200 x 140 x 75mm [7.9" x 5.5" x 3.0"]
	Carton	420 x 400 x 300mm [1'8" x 1'4" x 11.8"]
Weight	Model	270g [9.5oz]
	Package	520g [18.3oz]
Fixedness	Inter-locked power supply	
Power supply	5V 2A DC	
Power consumption	TBA	
Operation temperature	0~40°C [32~104°F]	
Storage temperature	-20~60°C [-4~140°F]	
Relative humidity	20~90% RH [no condensation]	

PANEL DESCRIPTIONS

Front Panel

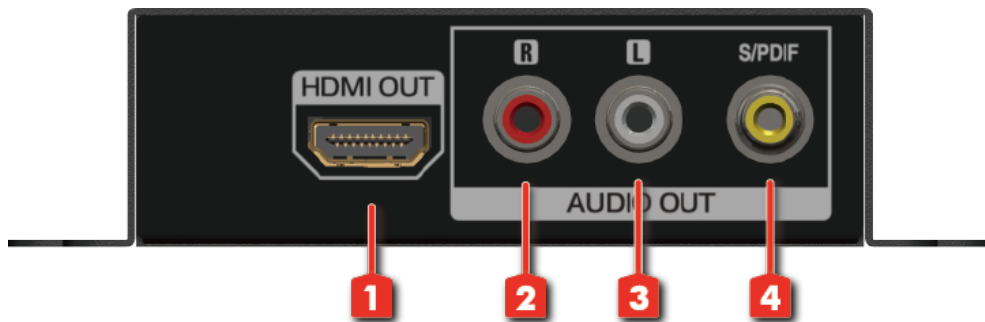

1. **HDMI OUT:** Connect to a HDMI display with a HDMI male-male cable here.
2. **Stereo Audio Output – R**
3. **Stereo Audio Output – L**
4. **S/PDIF Audio output:** connect to digital S/PDIF audio speaker

Rear Panel

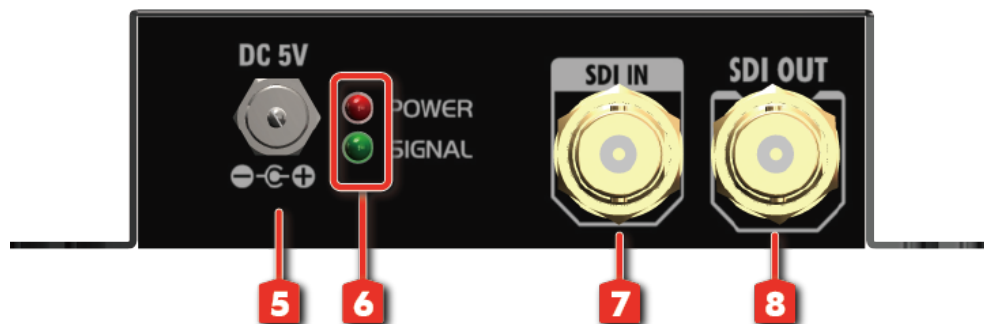

5. **+5V DC:** Connect to a 5V DC power supply
6. **Signal LED:**
 - <green> Both power and signal active.
 - <red> Only power active.
7. **SDI IN:** 3G/HD/SD-SDI Input#1
8. **SDI OUT:** 3G/HD/SD-SDI output #2

CONNECTION DIAGRAM

→ HDMI → SDI → AUDIO

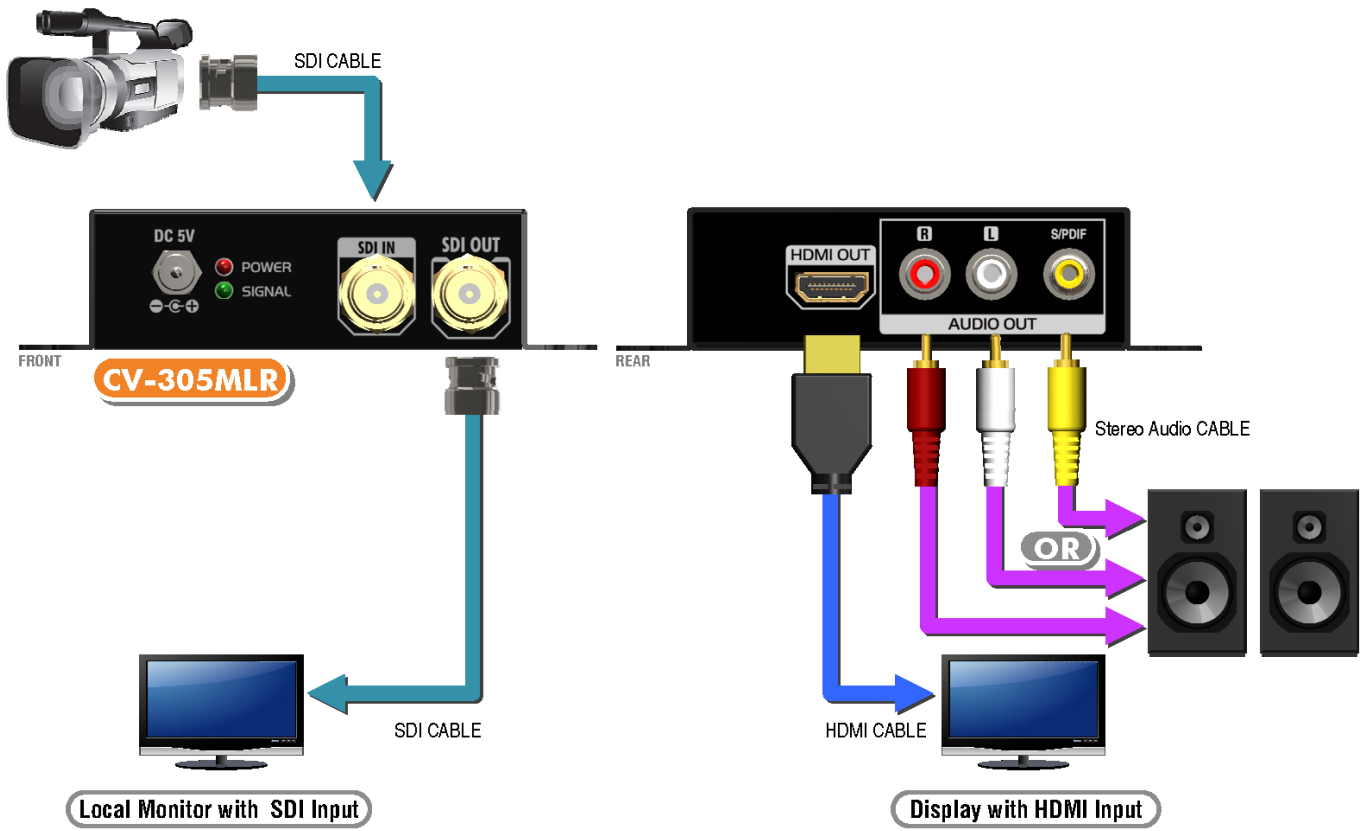

SUPPORTED RESOLUTIONS

3G OUTPUT	
1080p @ 50/ 59.94 / 60Hz	SMPTE 424M, SMPTE 425M
HD OUTPUT	
720p @ 50Hz	SMPTE 296M -3
720p @ 60 / 59.94Hz	SMPTE 296M -1, -2
1080i @ 50Hz	SMPTE 274M -6
1080i @ 60 / 59.94Hz	SMPTE 274M -4, -5
1080p @ 24 / 23.98Hz	SMPTE 274M -10, -11
1080p @ 25Hz	SMPTE 274M -9
1080p @ 30 / 29.97Hz	SMPTE 274M -7, -8
SD OUTPUT	
NTSC	
PAL B,D,G,H,I	

NOTICE

1. The CV-305MLR only embeds the audio channels in audio group 1 & 2.
2. The CV-305MLR supports audio sample frequency at 48kHz only.
3. Signal LED Indication:

	Green light	Red light	No light
Indication	Signal detect	Power On	Not supported format or no signal

WARRANTY

The SELLER warrants the **CV-305MLR 3G/HD/SD-SDI to HDMI Converter with Audio Extraction and Mixer support** with audio to be free from defects in the material and workmanship for 1 year from the date of purchase from the SELLER or an authorized dealer. Should this product fail to be in good working order within 1 year warranty period, The SELLER, at its option, repair or replace the unit, provided that the unit has not been subjected to accident, disaster, abuse or any unauthorized modifications including static discharge and power surges.

Unit that fails under conditions other than those covered will be repaired at the current price of parts and labor in effect at the time of repair. Such repairs are warranted for 90 days from the day of reshipment to the BUYER. If the unit is delivered by mail, customers agree to insure the unit or assume the risk of loss or damage in transit. Under no circumstances will a unit be accepted without a return authorization number.

The warranty is in lieu of all other warranties expressed or implied, including without limitations, any other implied warranty or fitness or merchantability for any particular purpose, all of which are expressly disclaimed.

Proof of sale may be required in order to claim warranty. Customers outside Taiwan are responsible for shipping charges to and from the SELLER. Cables are limited to a 30 day warranty and cable must be free from any markings, scratches, and neatly coiled.

The content of this manual has been carefully checked and is believed to be accurate. However, The SELLER assumes no responsibility for any inaccuracies that may be contained in this manual. The SELLER will NOT be liable for direct, indirect, incidental, special, or consequential damages resulting from any defect or omission in this manual, even if advised of the possibility of such damages. **Also, the technical information contained herein regarding the CV-305MLR features and specifications is subject to change without further notice.**